

Bassett Convergence System (BCS) User Manual



Man210	1.0.3	07/08/2014	Final	David Farnham	Phil Day
Manual No.	Revision	Date	Originator	Checked	Authorised for Issue

Contents

Section 1 : Introduction	3
Section 2 : Identify Components.....	4
Section 3 : Installation.....	6
3.01 Determine Linear Metreage of Tunnel and Sensor Spacing	6
3.02 Direction of view	6
3.03 Install Mounting Brackets	7
3.04 Install Pivot Pins	8
3.05 Install Short Arms (Sensors)	8
3.06 Install Long Arms	8
3.07 Dressing the Cable	11
Section 4 : Wiring	12
4.01 Install Data Logger.....	12
Section 5 : Document Installation.....	14
5.01 Pin Coordinates	14
Section 6 : Taking Readings / Logger Programming	16
Section 7 : Data Reduction	18
Section 8 : Calibration	19
Appendix A. Sample Installation Record Sheet.....	20
Appendix B. Sample Calibration Sheet	21

Section 1 : Introduction

The Soil Instruments Bassett Convergence System (BCS) is designed to monitor Δx and Δz displacements of structures and tunnels in near real-time.

The BCS system can be used for:

- Monitoring of tunnels to verify performance
- Monitoring deformation due to nearby construction activity
- Monitoring deformation in sprayed concrete tunnels under construction to ensure safety

The BCS uses solid state servo accelerometers for measuring deformation. These are highly resistant to electrical noise effects and mechanically very robust. As such they are ideally suited to harsh environments such as tunnels and construction sites.

The sensors are used to monitor the position of reference pins installed into the structure to be monitored. The sensors are linked to the pins via a system of low profile arms. Spatial displacement of any pin changes the tilt of the arms connected to it and results in a changed sensor output.

The system can be used as a closed loop or left open-ended. With closed loops, a Bowditch type correction can be applied to minimise the effects of errors. Open-ended systems are referenced to conventional surveys periodically unless one end is known to be stable, or only relative deformation are required.

Section 2 : Identify Components

An installed BCS consists of the following, from left to right;

Mounting Bracket - Pivot Pin
Short Arm & Sensor #1
Long Arm Sensor #1
Long Arm Coupler
Long Arm
Threaded Yoke

Mounting Bracket - Pivot Pin
Short Arm & Sensor #2
Long Arm Sensor #2
Long Arm Coupler
Long Arm
Threaded Yoke

Repeat for the number of sensor pairs in the system

Note: Final Mounting Bracket is required if the system is to be installed as an open loop.
Not required for closed loop.

Basset Convergence System Components

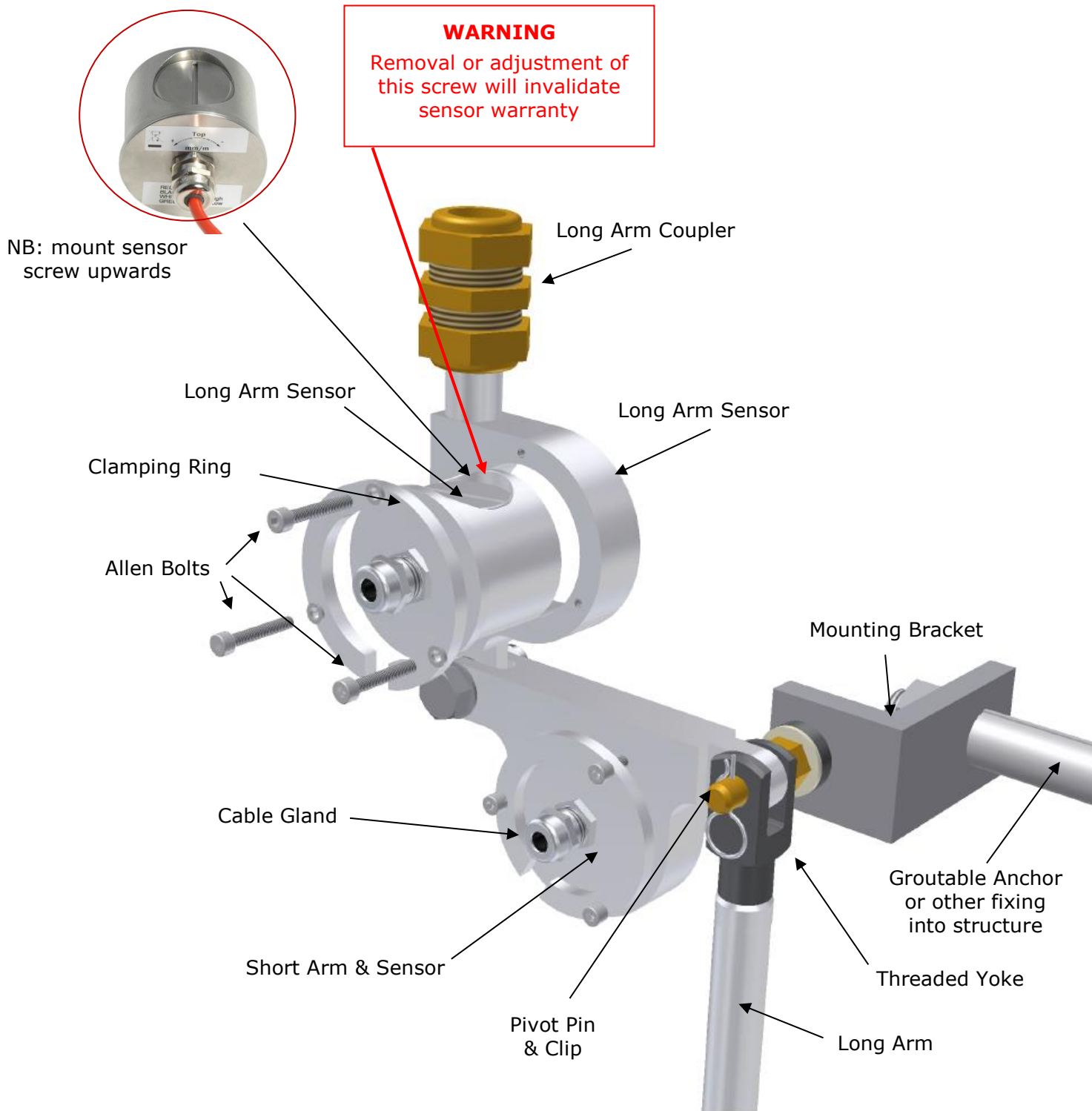

Section 3 : Installation

This manual covers the installation of the BCS, it does not cover the attachment of the mounting method bracket. This fixing method will depend on the tunnel type and construction.

The following tools are required for installation;

- 2 No Adjustable spanners or 16mm, 17mm, 24mm, 27mm and 30.5mm spanners
- Allen key 3mm
- Hacksaw to cut long arms to fit.
- 10 metre tape measure
- Small flat blade screwdriver and wire cutters (for wiring)

The installation procedure is detailed below in the following steps:-

- Establish a direction of view.
- Determine Sensor Spacing
- Install mounting brackets.
- Install pivot pins.
- Install long and short arms.
- Install data logging system.
- Test and zero sensors.
- Document installation.

3.01 Determine Linear Metreage of Tunnel and Sensor Spacing

Before installing the Bassett Convergence System, it is necessary to determine the linear metreage to be monitored and to set out the position of the system pivot pins, which should be as equidistantly spaced as possible.

Calculate the linear metreage by multiplying the tunnel diameter by p (3.14).

Calculate sensor spacing, is the system closed or open?

If closed, divide the linear radius by the number of sensor pairs, then multiply by 2 p .

If open, measure the size of the gap (typically the invert), then use the following equations

$$\text{missing part of loop} = \sin^{-1} \left(\frac{x/2}{r} \right) * r$$

Where X is the gap (invert) and r is the tunnel radius.

subtract this from the linear radius and divide by the number of sensors to get the sensor spacing.

Note: Remember you will need an addition end anchor for an open system

3.02 Direction of view

It is necessary to establish a convention to relate the computer display to the actual installation.

The computer screen will look similar to the drawing below.

“As-Installed” documentation must use the same direction of view. Starting from the lower left side, label the monitored positions A, B, C, D, etc, as shown below.

Two sensors will be installed for each monitored point, a short-arm sensor and a long-arm sensor. Starting from the lower left, label the sensors short No 1 & long No 1, short No 2 & long No 2, etc, as shown below.

NOTE: A closed system is shown. An open system would omit long arm No.10 and short arm No.10.

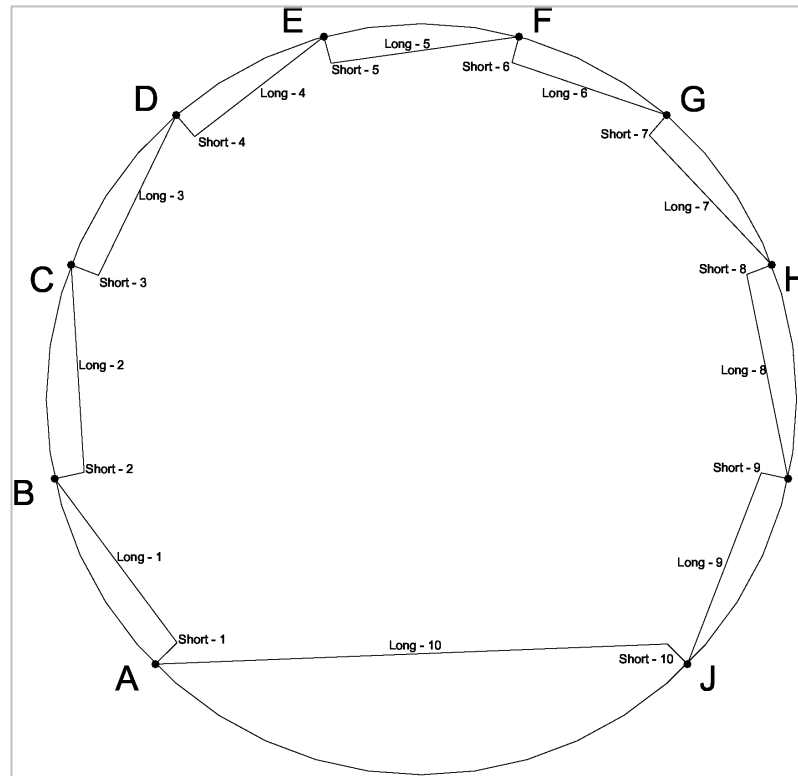

3.03 Install Mounting Brackets

Mark locations for mounting brackets so that the plane of Bassett section will be perpendicular to the structure.

Using a tape or a laser level, pick a point at the centre of the crown or invert and mark out from there.

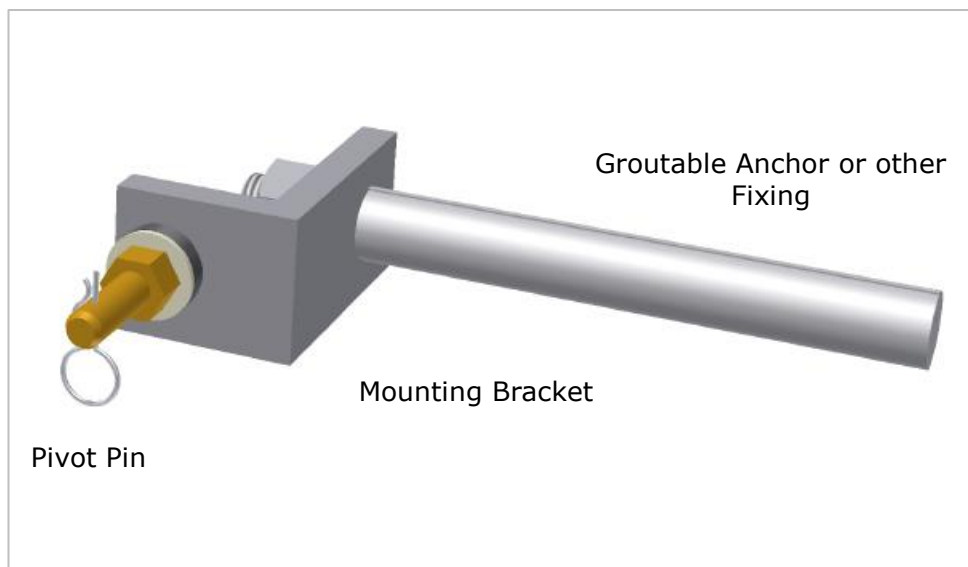

3.04 Install Pivot Pins

Fit a pivot pin to each mounting bracket. Pivot pins should all point the same way.

3.05 Install Short Arms (Sensors)

The short arm sensor should be installed at an angle of between 70° and 110° to the tunnel surface.

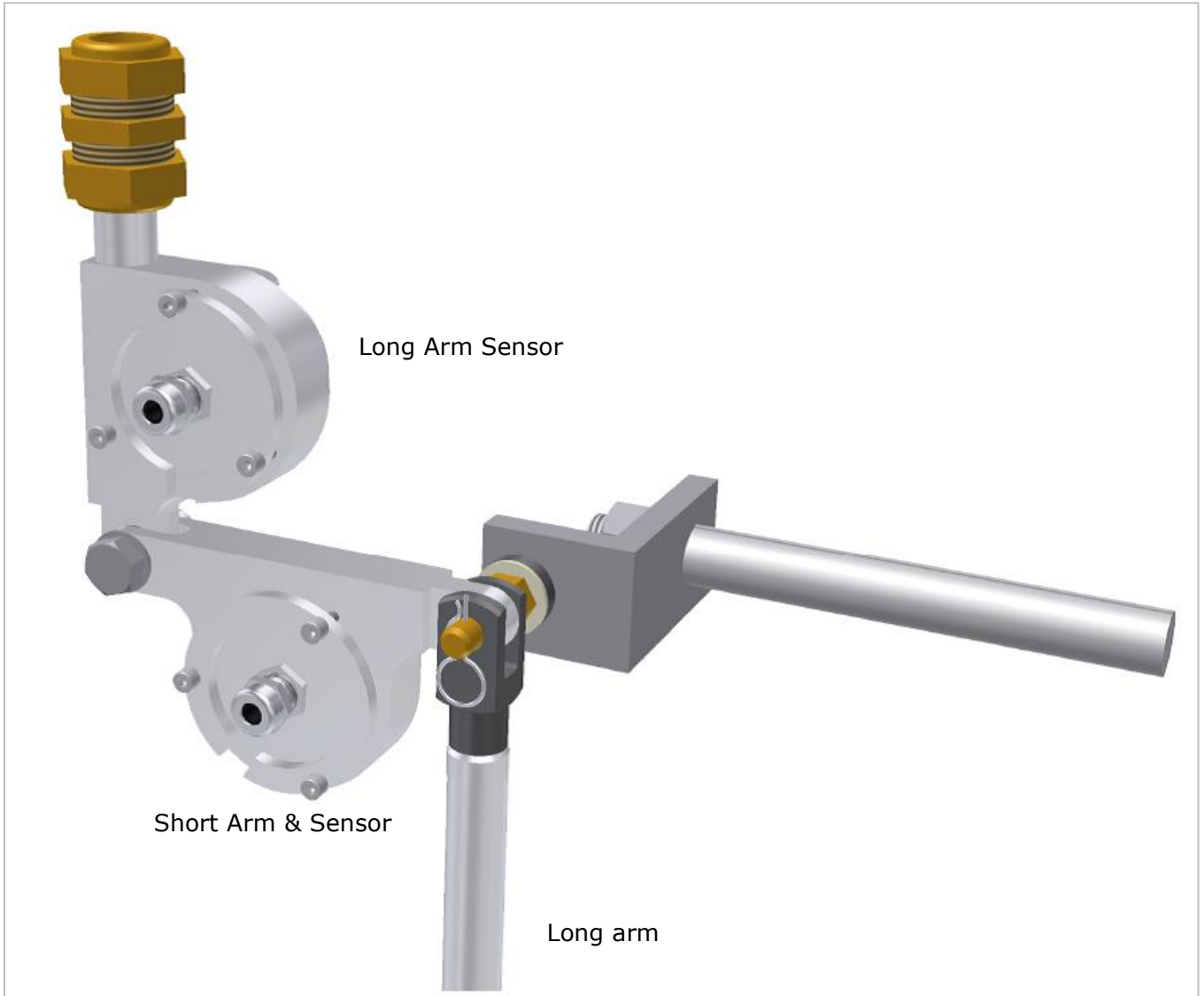

Start at the bottom pivot pin on one side. Do not work from both sides at once. Continue mounting short arms until you reach the last pivot pin.

3.06 Install Long Arms

Long arms are made from stainless steel tubing, which you must measure, shape to fit, and cut. Start at the bottom left and work your way around to the last pivot pin on the right (i.e. the direction of view).

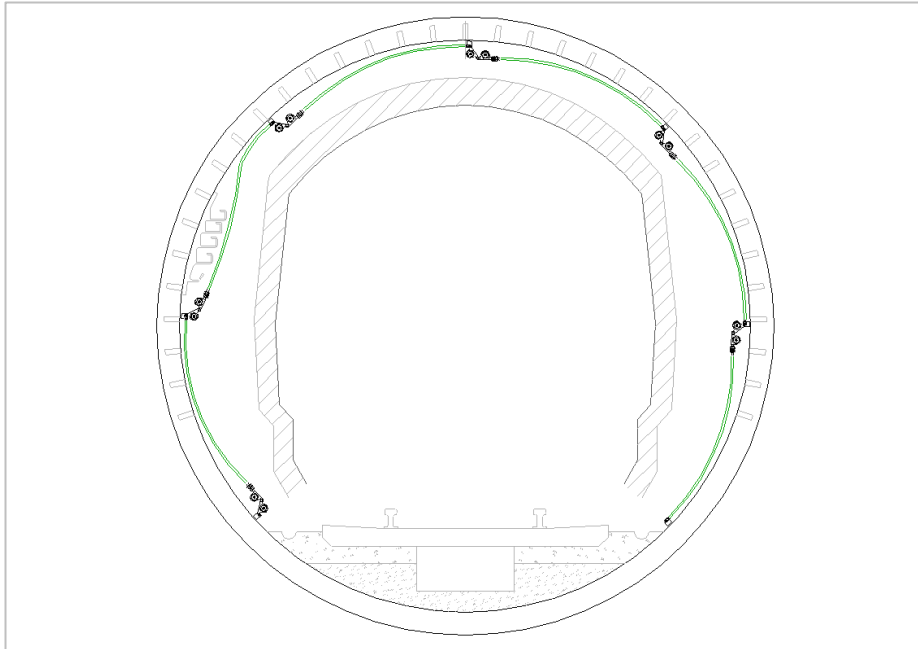

Measure Tubing

- Hold the first short arm perpendicular to the tunnel. Point its long-arm sensor at the next pivot pin.
- At the same time, hold the next long arm fitting (the one mounted on the next pivot pin) and point it back at the first pivot pin.
- Measure the distance between the two long-arm fittings. The tubing should fit all the way into the fittings. Allow extra length for the tubing if it is necessary to bend the tubing for clearance or to clear obstacles.

Bending and Cutting Tubing

- Bend tubing as required – we recommend using a professional plumbers tube bending tool
- Hold tubing in place and mark cut position – cut tubing

Check Length

- Install long arm
- Fit the long arm into both long arm fittings
- Repeat for remaining arms

Test for free movement then tighten screws

Zeroing the sensors

NOTE: Before zeroing the sensor, make sure that the sensor is mounted the right way up. Once all the sensors are installed they require zeroing (levelling).

Connect the sensor to a battery (8-16VDC) using the red (+ve) and black (-ve) wires, then measure the output voltage using a voltmeter. The voltmeter should be set on its DC voltage range which covers ± 2.5 volts. The white sensor wire goes to the red connector the green sensor wire goes to the black (comm.) connector.



Alternatively use an Soil Instruments IPI Readout



Slacken the 3 Allen bolts holding the clamping ring to the sensor arm. Only slacken as much as required to be able to turn the sensor with some resistance. If the sensor is too loose when tightening the bolts the sensor will move too much.

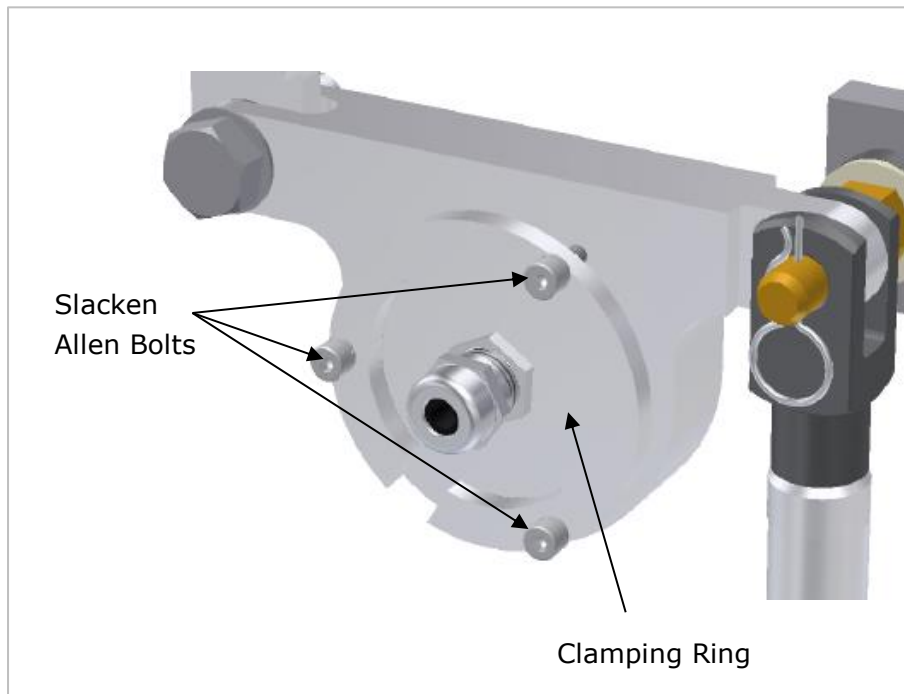

Adjust by rotating sensor housing until level (± 0.1 volts). When viewed from the cable entry side (as above) an anti-clockwise rotation will cause a positive change in the mV reading.

Carefully tighten the bolts, ensuring the sensor doesn't move. It is advisable to leave the readout connected during tightening.

3.07 Dressing the Cable

Starting at the end furthest from the data logger location, dress the cables around the BCS.

- Allow slack in the cable for strain relief where it passes sensors. This will be needed when the arms move.
- If possible, fix cable to tunnel lining rather than to the arms.
- Avoid crossing pivot points. Make a loop in the cable to avoid moving parts.

Section 4 : Wiring

The Soil Instruments BCS can be read by most commercially available data loggers. Soil Instruments recommend the Campbell datalogger range and can supply a fully built up datalogger with enclosure, logging program and a variety of communications options from a simple direct link to satellite modem, please see our datalogger datasheets.

We do not recommend that BCS is read with a manual readout as this defeats the objective of the BCS, where a traditional tape extensometer could be used, however if desired, a voltmeter can be used. (An external 8-16VDC power supply will be needed to do this).

Whatever the datalogger or reading method, the wiring remains the same. The sensors are supplied with a polyurethane-jacketed 4-core cable.

The cable has four conductors, a foil, screen and drain wire. The drain wire and screen should be connected to the ground terminal at the sensor input terminals for maximum resistance to induced voltages and interference. The sensor is a differential device and thus a + and - reading must be taken. The conductor colour codes are as per the table below:-

Conductor Colour	Identification
Red	Power+ (8-16VDC)
Black	Ground
White	Sensor Signal High
Green	Signal Low
Bare Wire	Drain (Screen)

Take extreme care whilst wiring to ensure conductors are correctly wired, especially the red power conductor. Always wire with the power switched off.

If it is desired to check the functioning of the sensors immediately after installation, at zero degrees tilt (i.e. true vertical or horizontal), the sensor output is approximately 0 VDC.

When wiring into a datalogger it is good practice to wire the lowest sensor to the first channel, the second sensor to the second channel etc. If a program not supplied by Soil Instruments is being used the following protocol should be observed to obtain the best results.

Power sensors on, wait for 3 seconds, take a minimum of 50 readings (differential voltage) at minimum 100 millisecond intervals and average.

4.01 Install Data Logger

Install data logger as close as possible to the BCS system to avoid long runs of signal cable.

- Cut off excess signal cable. Do not loop excess signal cable under the logger. This can cause interference from adjacent high-voltage cables.
- Before connecting signal cable to the logger, cut off dirty ends and strip insulation back to expose clean conductors.
- Wire the data logger as directed by the wiring diagram supplied with the logger. A typical wiring diagram is shown in the following.

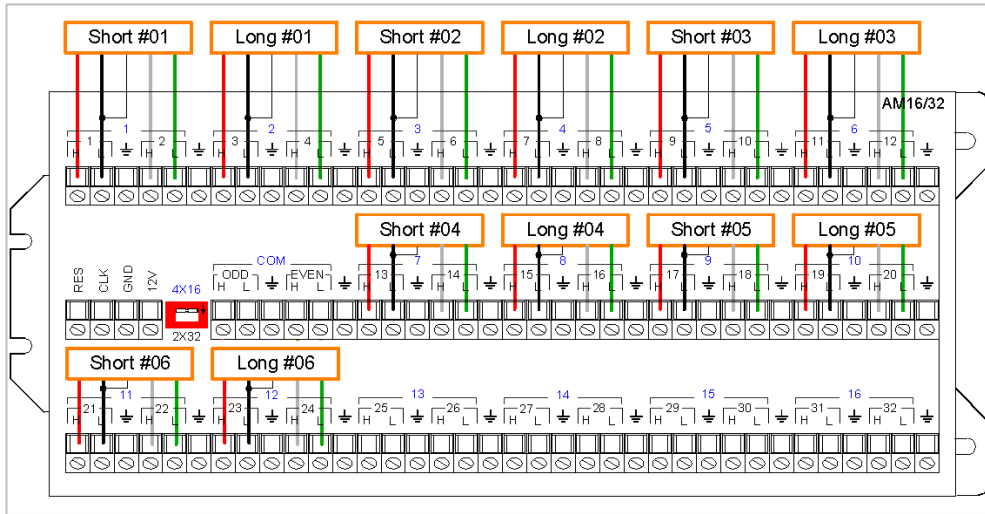

NOTE: For each sensor, drain wire for screen or shield should be connected to L1 terminal on AM16/32

Section 5 : Document Installation

Use the installation record in Appendix A to document the sensors.

Items to document are:

- Direction of view
- Sensor position
- Sensor serial number
- Sensor orientation (use raw readings)
- Zero reading
- Length of long arms

5.01 Pin Coordinates

Obtain the coordinates of all fixed pivot pins using an optical survey. In the example below, you would provide coordinates for pivot pins A through J.

Alternatively, you can measure distances from pin to pin, as shown in the drawing below. Measurements must be to the nearest mm. You must also provide the x and y distances between pins A and B, as shown in the drawing.

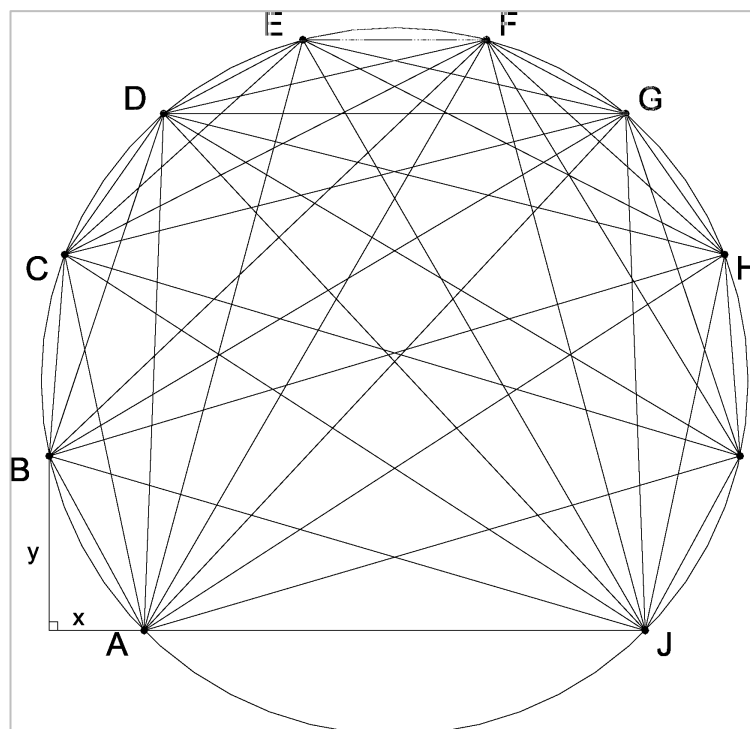

Distances Between Reference Pins (to nearest millimeter)

From \ To	A	B	C	D	E	F	G	H	I
A									
B									
C									
D									
E									
F									
G									
H									
I									
J									

X	
Y	

Section 6 : Taking Readings / Logger Programming

The Soil Instruments BCS sensors are designed to be read by Campbell datalogger systems. Other data loggers can be used, but the basic reading and excitation architecture outlined in this section must be followed.

Sensors should be read via a multiplexer (Campbell AM416 or AM16/32) and the following sequence must be used to ensure best sensor performance:

- Activate multiplexer
- Switch to first channel
 1. Switch on power supply to sensor (on Campbell loggers use the Switched 12Volt option)
 2. Let the sensor warm up for at least 3 seconds
 3. Take a minimum of 50 differential measurements and store the average
 4. Switch power to the sensor off
 5. Switch to the next channel
- Repeat step a) through e) for the next sensor
- De-activate multiplexer

NOTE: a sample program for a CSI CR10X unit is printed below – for CR800 and CR1000 programs, please contact Soil Instruments.

Sensors can be left powered when not being read, but for maximum life we do not recommend this. When using multiplexer units this is not possible and the above sequence should be observed.

When long cables are used make sure to increase the settling time for the datalogger measurements to achieve optimal performance.

These sample CR10X instructions below assume:-

```
C1 = Act-multiplexer 1
C7 = Act Switched 12Volt
C8 = CLK pulse for multiplexer
Measuring channel is differential channel 1
Multiplexer = CSI AM16/32 (in 4x16 mode)

; Set C8 for CLK pulse
; Activate multiplexer 1 on C1
1: Set Port(s) (P20)
1: 4000   C8..C5 = 10ms/low/low/low
2: 0001   C4..C1 = low/low/low/high

;Start a loop for 16 BCS sensors (8 Short & 8 Long Arms)
2: Beginning of Loop (P87)
1: 0000   Delay
2: 16     Loop Count

; Send a CLK pulse
3: Do (P86)
1: 78     Pulse Port 8
```



```

; Activate SW12Volt
4: Do (P86)
  1: 47    Set Port 7 High

; Let the sensors warm up for at least 3 seconds
5: Excitation with Delay (P22)
  1: 3     Ex Channel
  2: 0000  Delay W/Ex (0.01 sec units)
  3: 300   Delay After Ex (0.01 sec units)
  4: 0     mV Excitation

; Start a loop for 50 measurements
6: Beginning of Loop (P87)
  1: 0000  Delay
  2: 50    Loop Count

; Measure the sensors differential on channel 1
7: Volt (Diff) (P2)
  1: 1     Reps
  2: 5     2500 mV Slow Range
  3: 1     DIFF Channel
  4: 2     -- Loc [ measmV_01 ]
  5: 1.0   Multiplier
  6: 0.0   Offset

8: End (P95)

; De-Activate the SW12Volt
9: Do (P86)
  1: 57    Set Port 7 Low

; Take the Average of the measurements and store it
10: Spatial Average (P51)
  1: 50    Swath
  2: 2     First Loc [ measmV_01 ]
  3: 1     -- Avg Loc [ BCSmV_01 ]

;End of Loop
11: End (P95)

;De-Activate multiplexer 1
12: Do (P86)
  1: 51    Set Port 1 Low

```

If in any doubt we recommend contacting Soil Instruments for advice. The performance of the sensors as calibrated is not guaranteed unless the above protocols are used.

Soil Instruments can supply full logger programs and wiring diagrams at an extra cost, please contact us for details.

Section 7 : Data Reduction

The Soil Instruments BCS sensor is calibrated over ± 2 arc degrees (long arm) or ± 10 arc degrees (short arm) - (approx. ± 35 or ± 175 mm/metre) and has a DC voltage output dependant on tilt.

The sensors are calibrated for tilt only (please see note on temperature below) and the unit of calibration (either Arc Degrees or mm/metre) is specified at the time of order. The calibration certificate supplied with the sensor (please see section 6) contains the following information: -

- Instrument Type
- Serial Number
- Range
- Calibration Data (both raw and reduced)
- Conversion Formula
- FS Error % at each calibration point
- Wiring Code

Note: Once the polynomial formula has been calculated the resultant must be multiplied by the gauge length of the sensor, measured during installation, to give correct cumulative deflection calculations, unless only individual arc degree rotations are required.

A positive resultant indicates anti-clockwise rotation (-mm); a negative resultant indicates clockwise rotation (+mm).

The calibration factors can easily be loaded into a spreadsheet and data added via cut and past or an automated program such as Argus can be used, in which case the application of calibration factors and gauge length is fully automatic.

The MEMS Accelerometer chip used in the BCS sensor is calibrated for temperature as part of the micro-machine manufacturing process by the chip manufacturer. As well as the MEMS tilt element the sensor contains a microprocessor and a look up table to apply correction for temperature changes to the silicon substrate within the sensing element. Soil Instruments has no control over this process other than by the QA procedures followed by the chip manufacturer, which specify the correction and rejection criteria.

The sensor output is therefore corrected automatically for the effects of temperature on the accelerometer chip. Please note that this correction will not apply to unknown factors within the sensor string or borehole where an external change may well be occurring. Soil Instruments do not offer the sensor with an on-board temperature sensor. If temperature measurement is desired, then a separate temperature sensor must be installed additional to the BCS sensor.

Section 8 : Calibration

Calibration frequency of Instrumentation is generally dictated by contract or regulation requirements. Additional guidelines can be offered by the manufacturer if needed.

For Instruments that are not installed in fixed positions ie portable, or are not required for continuous monitoring, the manufacturer would advise that where possible annual calibration is recommended. Regular calibration of portable instrumentation is essential as the instruments are more exposed to various influences.

Manufacturer guidelines are intended to be guidelines only, many factors might influence the calibration frequency decision. Some of these factors might be usage, system performance indicators and environmental effects. The users should conclude the calibration requirement based on all factors presented.

Instrumentation that is installed for long term monitoring of structures should be calibrated pre installation. Following installation further calibration periods should be decided based on monitoring requirements and system performance. Commonly due to instrumentation being installed in an environment where it remains untouched calibration periods might be further apart.

Typically instruments are not recalibrated during long term monitoring of a structure unless results have raised concern and there is call for the instruments to be verified.

Appendix A. Sample Installation Record Sheet

Project Title:

Date of Installation:

Direction of View:

Project Engineer:

Sensor	Serial Number	Rotate Sensor clockwise. Does reading increase (+) or decrease (-)? Mark the appropriate column		Zero reading	Arm length: the straight line distance from pin to pin mm
		+	-		
Short arm #1					
Short arm #2					
Short arm #3					
Short arm #4					
Short arm #5					
Short arm #6					
Short arm #7					
Short arm #8					
Short arm #9					
Short arm #10					
Long arm #1					
Long arm #2					
Long arm #3					
Long arm #4					
Long arm #5					
Long arm #6					
Long arm #7					
Long arm #8					
Long arm #9					
Long arm #10					

Appendix B. Sample Calibration Sheet



BS EN ISO 9001:2008
FM 553710



Bell Lane, Uckfield, East Sussex t: +44 (0) 1825 765044 e: sales@itmsoil.com
TN22 1QL, United Kingdom f: +44 (0) 1825 744398 w: www.itmsoil.com

itmsoil Holdings Ltd. Registered in England. Number: 4239206. Registered Office: Bell Lane, Uckfield, East Sussex TN22 1QL.

Sensor Type **BCS - Long Arm Sensor**

Model No **2176-143/02**

Range **± 2 Degrees**

Calibration **Rotary Table S/N 21900871D**
Equipment **S/N Soil Equip No 1749**

Date **01-Apr-2009**

Ambient Temp **20.0 °C**

Serial No **BCS 5027**

Calibrated By **J. Kingshot**

Calibrated Data

Position		Raw Data mV	Degrees Polynomial		mm/m Polynomial		Full Scale Error %FS
Degree	mm/m		Calculated Polynomial Displacement	ArcDeg non- conformance	Calculated Polynomial Displacement	mm non- conformance	
-2.0	-34.90	2462.0	-2.000	0.000	-34.90	0.00	0.00
-1.6	-27.92	1969.0	-1.600	0.000	-27.92	-0.01	-0.01
-1.2	-20.94	1477.0	-1.200	0.000	-20.94	0.00	0.00
-0.8	-13.96	985.0	-0.800	0.000	-13.97	0.01	0.01
-0.4	-6.98	492.0	-0.400	0.000	-6.98	0.00	-0.01
0.0	0.00	0.0	0.000	0.000	0.00	0.00	0.01
0.4	6.98	-492.0	0.400	0.000	6.99	0.01	0.01
0.8	13.96	-982.0	0.799	-0.001	13.94	-0.02	-0.03
1.2	20.94	-1476.0	1.200	0.000	20.95	0.01	0.01
1.6	27.92	-1968.0	1.600	0.000	27.92	0.00	0.00
2.0	34.90	-2461.0	2.000	0.000	34.90	0.00	0.00

Conversion Factors

Polynomial Factors (mV to mm/m)
$b_0 = 0.004744$
$b_1 = -0.014195$
$b_2 = 3.954273E-09$
$b_3 = 3.659975E-12$
$b_4 = -6.307894E-16$
$b_5 = -1.591375E-19$

Polynomial Factors (mV to ArcDegrees)
$b_0 = 0.000272$
$b_1 = -0.000813$
$b_2 = 2.266075E-10$
$b_3 = 1.823969E-13$
$b_4 = -3.614277E-17$
$b_5 = -9.106232E-21$

Conversion Formula

Displacement = Current Reading - Initial Reading

Reading = $b_0 + b_1X + b_2X^2 + b_3X^3 + b_4X^4 + b_5X^5$

(where X is the raw sensor data in mV)

The instrument detailed hereon has, as applicable, been tested and calibrated in accordance with procedures, which are part of our ISO9001:2008 Quality Management System, and unless otherwise indicated, performs within +/- 0.05% as specified. Thus, the in

Certified By _____

Line Manager



Bell Lane, Uckfield, East Sussex
TN22 1QL United Kingdom

t: +44 (0) 1825 765044
f: +44 (0) 1825 744398

e: info@itmsoil.com
w: www.itmsoil.com

Soil Instruments Ltd. Registered in England. Number: 07960087. Registered Office: 5th Floor, 24 Old Bond Street, London, W1S 4AW